

Tomasz Podeszwa, Joanna Harasym

Department of Biotechnology and Food Analysis, Faculty of Engineering and Economics, Wrocław University of Economics

Komandorska 118/120, 53-345 Wrocław, tomasz.podeszwa@ue.wroc.pl

NEW METHODS OF HOPPING (DRYHOPPING) AND THEIR IMPACT ON SENSORY PROPERTIES OF BEER

Abstract

Due to the significant changes on the beer market the flourishing development of small and craft breweries is clearly observed. Upgraded consumers' expectation led to many technological challenges in brewing process resulting in novel methods of manufacturing of many different beer types. As bitterness and aroma are two crucial quality features of beer and many scientific efforts have been done especially in the area of hop aroma. Despite the predominant impact of main beer flavor compound e.g. linalool, other substances also contribute to the hoppy beer aroma through additive or synergistic effects not only raw materials used but also hopping regimes contribute as well to final flavor release though several new methods of hopping, particularly dry hopping have been developed.

Key words

Hop, dry hopping, beer, bitterness, aroma, hopping

Hops as a raw material in brewing

Hops (*Humulus lupulus L.*) is a perennial, dioecious plant belonging to the *Cannabaceae* family. The brewing industry utilises only the female hops in the form of whole cone or their products (granulates or hop extracts) containing bitter resins, polyphenols and essential oils. They contribute to beer the bitter and aromatic substances [1]. Bitter substances (hop resins) consist 10-30% of the dry weight of hops (d.w.h.). These substances are divided into soft resins (9-27.5% d.w.h.), which include alpha-acids and beta-acids and hard resins (1.5-2.5% d.w.h.) [1, 2]. For a long time, hard resins were considered useless in brewing, but recent studies delivered information that the hard resins positively contribute to the foam stabilising properties, impact all analysed attributes in sensory analysis and with increasing concentrations, higher bitter intensities were recorded [3, 4].

Alpha-acids (1.5-18% d.w.h.), also known as humulons, have the greatest importance in shaping the beer distinctive bitterness. The alpha-acids are the following compounds: humulon, cohumulon, adhumulon and alpha-acids are formed in result of the transformation of beta-acids (2.5-8% d.w.h. into lupulon, colupulon, adlupulone) during the maturation of the plant. This reaction is closely dependent on environmental conditions. With sunny weather during the summer months more beta-acids are transformed into alpha-acids than during the rainy and cold summer. The ratio of alpha-acids to beta-acids can range from 0.5 to about 4. Not all alpha-acids favorably affect the quality of bitterness in the beer. Such more intensive bitterness is delivered by cohumulone, therefore, cultivation methods aims to maintain the cohumulone level not more than 25% of the total content of alpha-acids in aroma hops and 35% in bitter hops. Insoluble alpha-acids are converted with high temperature into soluble iso-alpha-acids (isohumulone, isocohumulone, isoadhumulon), giving the beer a bitter taste [1, 2].

Bitter substances beneficially contribute to the persistence of foaming due to surface tension reduction. Also exhibit a bacteriostatic activity, however, not large enough to effectively raise the microbial durability of beer. Alpha- and beta-acids are unstable substances, which are constantly changing in the conditions of high temperature, humidity and oxygen availability. It is estimated that during storage in temperature of 18 °C during 2 months around 25% of alpha-acids may be further converted and product of the oxidation of both alpha- and beta-acids are hard resins. It is worth noting that their further conversion of hard resin may lead to the formation of valeric acid, which gives the beer an intense smell of cheese. In view of the above, extremely important for appropriate storage conditions of hops is avoiding access of air in the dry and cooled stores [1, 2, 3, 4].

Hop oils in hops occur in quantities from 0.5 to 4% d.w.h. This is a complex combination of different volatile substances. Their composition is varietal characteristic distinct for individual species of hops. Hop oils in 50-80% consist of hydrocarbon compounds (monoterpenes like myrcene; sesquiterpenes like caryophyllene, humulen, farnesene; aliphatic hydrocarbons like pentane or octane, in 30% of oxidised compounds (terpenic alcohols like linalool, geraniol; oxidized sesquiterpenes like epoxides, alcohols; others like aldehydes, esters, ketones) and about in 1% of sulfur compounds [2, 5]. The Table 1 presents classification of hop oil.

Table 1. Hop oil classification

hop oil		
hydrocarbons	oxygenated compounds	sulphur-containing compounds
monoterpenes (myrcene)	terpene alcohols (linalool, geraniol)	thioesters
sesquiterpenes (beta-caryophyllene, farnesene)	sesquiterpene alcohols (humulenol I+II, humulol)	sulfides (DMS)
aliphatic hydrocarbons	others (alcohols, epoxides, ketones, esters)	other sulphur compounds

Source: Own work based on [6]

The component with the highest content in essential oils (20 – 70%) is volatile and very susceptible to oxidation is the monoterpene myrcene. Threshold of perceptibility for myrcene in the beer is about 120 µg/l. Its concentration in beer (ranging from 0 to 200 µg/l) with other more or less volatile constituents of essential oils, depends not only on their individual content in essential oils of hop varieties, but also from the size of the administered hops dose and the regime of hopping [2].

Dry-hopping methods significantly raise the aroma substances content in beer. Myrcene provides to beer the very wide spectrum of taste and flavours from the strongly resinous pine, herbal, grassy to an aromatic citrus and floral [2]. These flavour features can be disrupted by the presence of oxidized myrcene derivatives resulting during traditional hop boiling [2]. These compounds form the unpleasant oxidative taste of beer [2].

Also, other significant components of essential oils (e.g. sesquiterpenes like humulen and caryophyllene) undergo oxidation in hops, but their oxidative derivatives are compounds with beneficial effects on the quality of the flavor characteristic in the beer. Those oxidation phenomena are strongly limited during dry hopping but it is worth mentioning that those oxidised derivatives of myrcene (and other ingredients of essential oils) are primarily formed during the processing and storage of hops conditions [2].

The most important and crucial compound forming a hop aroma in beer, and, in particular, the pleasant citrus, floral and fruity notes is the terpene alcohol linalool; especially when it appears in beers at concentrations above its threshold of perceptibility (27 µg/l). Another sensory beneficial terpene alcohol - geraniol with threshold of perceptibility of 36 µg/l provides the beer the floral and citrus scents, likely alpha - terpineol, who is related to creating the taste of resin [2].

It has been shown that during wort fermentation the yeast of the genus *Saccharomyces* converts the aromatic hop compounds such as eg. linalool or geraniol to other aroma compounds such as citronellol (responsible for a pronounced citrus aroma of beer) or alpha-terpineol [7, 8, 9]. Alpha-terpineol significantly complements the noble hop aroma in the beer composing greatly with sensory beneficial sesquiterpenes of essential oils like caryophyllene, humulen and farnesene, which are components of high content in essential oils of many hop varieties and bring the beer the resin, herbal and spicy scents. All these components and other esters, aldehydes and ketones of essential oils as well as products of fermentation of beer, have a smaller or a larger contribution in the formation of hop scents. In beers of top and bottom fermentation they differ due to the qualitative and quantitative variations of the fermentation by-products [5].

The classic hopping methods in brewing industry

A classic approach for the use of hops in beer production is its addition during the boiling of wort. The varieties of highly content of bitter hops with high amount of alpha-acids should be introduced into the boiling process

at the beginning while the highly aromatic hop varieties should be added on the last 0-10 minutes. Boiling hops with the wort is followed by dissolution of the hop resins (mainly alpha-acids) and their isomerisation to the iso-alpha-acids, resulting in the formation of characteristic bitterness in the beer. Dissolution are also subjected the essential oils of hop which are responsible for the formation in the beer of distinctive hop aroma. The introduction of hops at the end of the cooking process results in extraction of essential oils from hops and their preservation in the wort. The type of aroma is less stable and could be seriously weakened after pasteurisation of beer (mainly after tunnel pasteurisation); relatively quickly disappear also during beer storage [10].

Other techniques of hops use during brewing (mash hopping, hop tea, hop back, first wort hopping, hop extracts, cold hopping)

As a result of the search for specific hop derived sensory characteristics of the final beer, apart from classic approach of the hops use in brewing, there are many techniques and methods of using hops at different stages of the production of beer. They all are focused on one common goal - obtain gentian and extraordinary hop flavour.

One of such methods is First Wort Hopping - FWH. This method involves adding hops to first wort, during lautering. This is a way to obtain very delicate, pleasant bitterness of beer and noble hop aroma. Another method is the mash hopping - MH, which is based on adding a part of the aromatic hops already at the stage of mashing. This treatment is designed to deliver to beer the hop taste and appropriate hop variety aroma. Hopping method based on adding hops to the wort after the end of cooking in a tank called whirlpool (swirling wort during cooling) when the temperature is less than the approx. 80 °C and higher than 60 °C. The use of such parameters impedes isomerisation of alpha-acids and facilitates dissolve the aromatic oils in wort. Hop back hopping involves passing of warm wort by the special device filled with hops. This way hopped beer increases aroma. Hop Tea hopping procedure is a method that involves hops infusion in the water or in a serving of wort and the addition of such infusion into the final beer [11].

Dry hopping

Dry hopping method is based on addition of hops to beer during lagering. This technique is designed to give to final, strongly hopped beer much more intense aroma. The resulting effect is different than when aromatic hop varieties are added at the end of the wort boiling. The differences in final effect between these techniques of adding aroma have been verified applying hops metabolomics [12, 13]. During dry hopping the alpha-acids are not isomerised so this method causes a negligible probability of increasing bitterness during fermentation. However, it has been shown that low alcohol content in beer allows the extraction of polyphenols and other compounds during the dry hopping, which to a small extent can contribute to increase the bitterness of beer [14, 15].

Slight increase in bitterness in the beer is not the essence of this technique. Dry hopping primarily is used to increase the extraction of essential oils and other aromatic compounds from hops to impart hoppy aroma to beer. Hoppy aroma is dependent on the characteristics of the used hops and can introduce to beer the resin, spicy, herbal, fruity, citrusy, earth or other scents. The popularity of this method is noticeable especially in craft breweries around the world which, unlike big breweries, produce beers in a variety of styles not only lager type beer, using new varieties of aromatic and gentian hops. It is worth mentioning that it is believed that this technique comes from the UK, however, the resurgence of the popularity of this method occurred in craft breweries of United States. Due to the fact that dry hopping takes place at relatively low temperatures, thermal degradation and loss of the aromatic substance are significantly reduced. This allows obtaining of a higher concentration of these compounds in the finished beer [10]. In addition, the dry hopping can intensify the impression of bitterness due to interactions with the hoppy aroma, increases the polyphenol content in beer, affect colloidal stability of beer, improves the stability of taste, increases the stability of foam, and provides more drinkability of beer [16].

Dry hopping methods

The traditional dry-hopping

Dry hopping as the technology draws increasing attention especially within craft and home breweries. Usually whole hop cones, ground hops or pellets are infused into cold beer to transfer in particular aroma components

with low losses (no evaporation) and reduced chemical transformations. This technique is still novel and there are a few statements available on the technology and technique of dry hopping [17]. Grinnell [17] emphasises the particular difficulties exists with reproducible transfer of hop substances with dry hopping. Also scaling up leads to several problems with aroma and flavor lost [18].

Dry hopping is usually accomplished by dropping hops directly or in special hop-bags into the fermentation tank from the top hatch (Fig. 1). Another way is pumping green beer from primary fermentation tank into a sterile secondary maturation and storage tank or very seldom from secondary into tertiary fermentation tank with hop-bags (Fig. 2). Unfortunately, these classic approaches lead to many technological problems.

The addition of hops in the bags reduces the contact of hop cones or pellets with beer, so with this solution, it must reconsider the poor performance of hop oils and aromatic compounds extraction into beer. Additionally, particles of hops passing the mesh of the bag can result in large beer haze and finally in its gushing.



Figure 1. Hop bag addition into fermentation tank.
Source: own work based on [11]

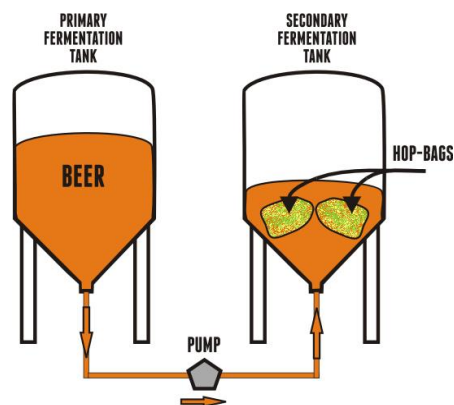

Figure 2. Hop bag addition into secondary fermentation tank.
Source: own work based on [11]

Novel dry hopping systems

Solving problems of extra hop aroma adding to the beer has led to various modern dry-hopping procedures such as hop cannons, torpedoes or hop rockets. Hop cannons utilise pressurised CO₂ as transportation force to move hop pellets through the connected pipe into the top of the fermentation tank (Fig. 3). Hop cannons are designed as pumping device pushing beer through a hop bed and countercurrently extract significant hop aroma and flavour (Fig. 4). These processes reduce the possibility of dissolved oxygen uptake and prevent further oxidation. The all methods used for hopping after boiling aim in exhaustive extraction of hop cones leading to recovery of all the essential oils flavouring beer.

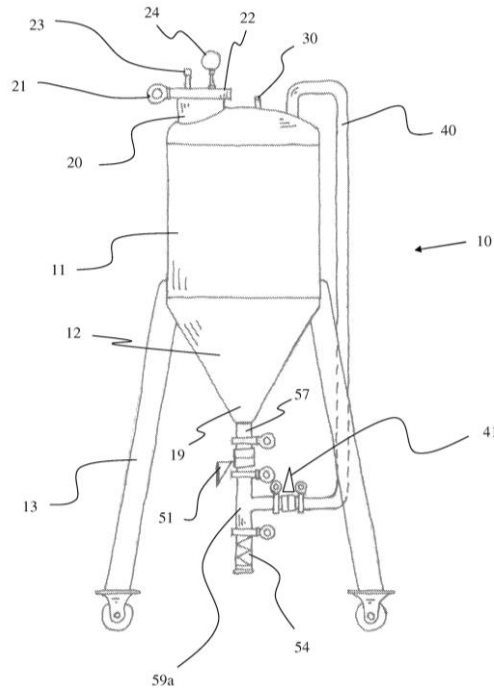

Figure 3. Diagram of a hop cannon. 10 – hop cannon, 11 – main body, 12 - a cone shaped lower end section, 13 – legs with wheels, 19 – exit port , 20 – material port, 21 – hinge, 22 - lid plate, 23 – fluid connection, 24 – pressure sensor , 30 – release valve, 40 – bypass pipe, 41 – bypass valve, 51 – material valve, 54 – sight glass , 57 - material pipe, 59a - middle branch of the tee.

Source: based on [19]

HopGun system from Braukon is also widely used. After filling HopGun tank (1) with cones of hops or pellets during the phase of dry hopping the contents of the tank circulates (2) until the saturation of hop flavourings reaches the required degree. Valuable hop oils and aromas are released and then the suspension is back by a specially designed perforated internal candle of HopGun tank. Insoluble particles of hops are retained in the tank (Fig 4. part 3).

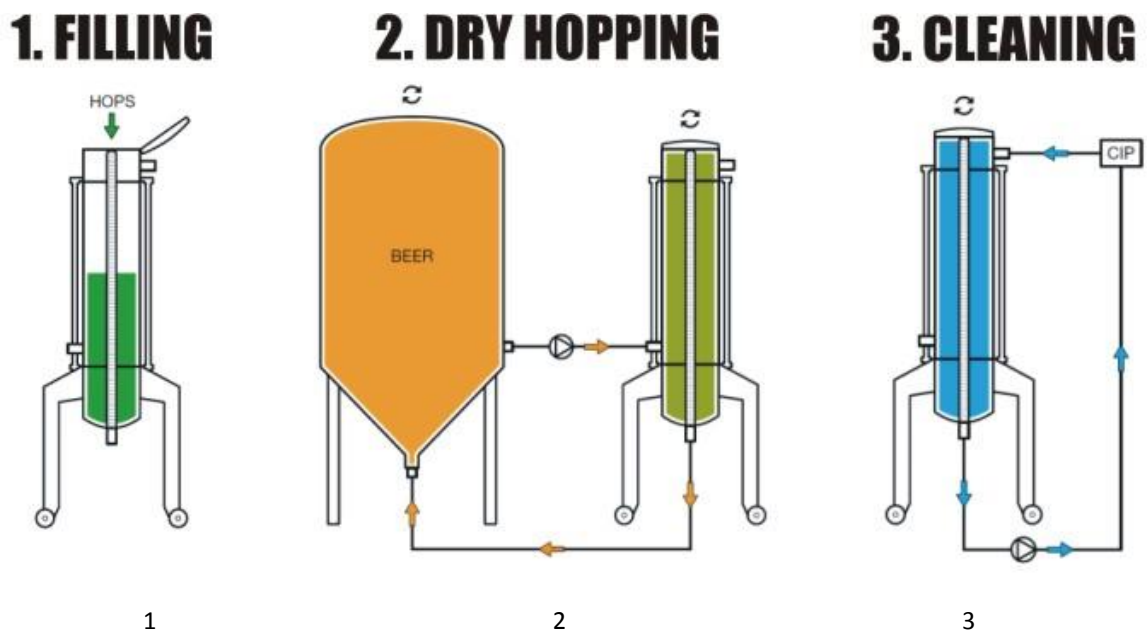

Fig. 4. HopGUN system procedure.

Source: <http://braukon.de> [20]

Other supportive actions as additional milling are designed for enlarging the efficacy of dry hopping. One of them is ROLEC DryHOPNIK system using an external milling for hop dispersion in an external loop of green beer. The loop is pressurised to avoid overfoaming and related beer loss. An inert gas - CO₂ is injected to tank with hop to avoid oxygen pick-up. One batch of hop pellets fills the hop dosing vessel. Milling chamber serves also as mixing tank, so further mixing with beer is not necessary [21].

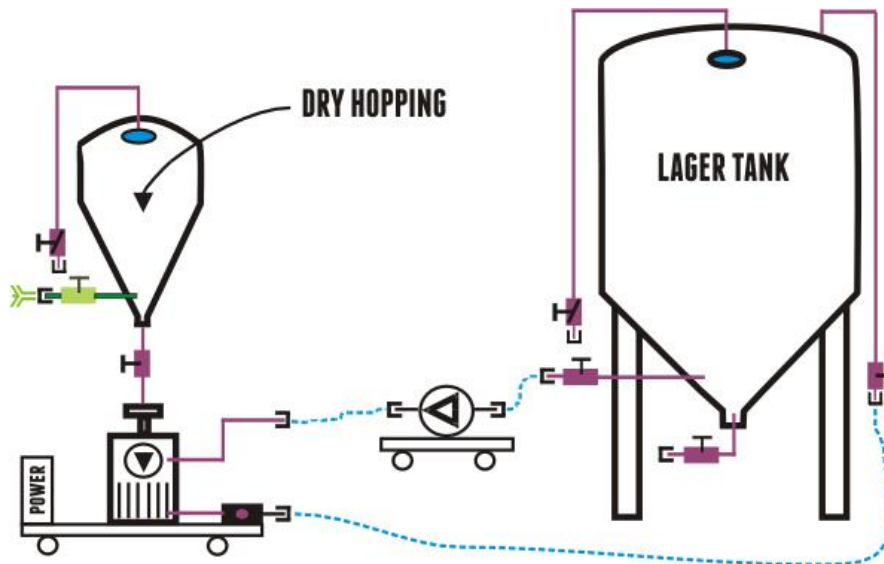

Figure 5. Rolec-DryHOPNIK System.

Source: www.rolec-prozess-brautechnik.eu [21]

Comparing those solution it has to be noted that the problems rising from reduced contact between hops and beer which appears in traditional solutions using bags and resulting poor extraction yield was solved with fixed bed of hops which is used by hop cannons (Fig.3). The increase of such extraction was obtained and controlled with circulation of beer through perforated internal candle of HopGun system (Fig. 4) . Enlargening scale of dry hopping with exhaustive extraction was obtained during additional milling of hops and mixing within DryHOPNIK system (Fig.5).

Summary and conclusions

The popularity of the dry hopping methods, launched through the development of craft brewing in the United States, so far brings many benefits in brewing technology. It has developed the science of hops use technology and led to better understanding of aromatic compounds of hops. The responsible for the citrus flavour of beer is supposed to be (among others) beta-citronellol, which is the result of bioconversion of geraniol due to metabolism of yeast and synergistic action of linalool with geraniol and citronellol. This knowledge have started continuous research on new varieties and hybrids of gentian and aromatic hops application. Gradually they are placed on the market and described as new hops. Most of all new varieties over the past few years, was cultivated in the United States, Germany, Australia and New Zealand.

The elimination of technological problems resulting from the application of classical methods of the hopping led to the creation of compact solutions performing enhanced extraction of essential oils and hops aroma in beer while reducing the consumption of hops (up to 50%) [2]. Device types as Hop Gun, Hop cannon, Torpedoes, DryHopnik Systems and other are mobile devices that can handle all the tanks at the brewery, regardless of their location. Thanks to this breweries save space and money avoiding solutions where intermediate tanks are required for the extraction of hops.

Dry hopping method has several advantages, both economical and sensorial. Despite the mobility and space saving design, also the process of hopping during fermentation deserves better attentions. As it is often performed during active fermentation – the yeast capable of metabolising hop derived component significantly contribute to development of novel flavourings.

Their transfer rates of hop substances during dry hopping which can provide a great variability of application is still not well elaborated. Forster [17] showed that from the all α -acids dosed to beer only 4 to 5% can be found in the beers, of the total polyphenols 50 to 60% and of the low-molecular polyphenols 60 to 70%, while terpene hydrocarbons reveals yields of about 3%; linalool transfers to about 100% and geraniol seems to react variety-specific. Geraniol seems to be converted during dry hopping and released also from geranyl acetate achieving finally total yield (from geraniol and geranyl acetate in hops) from 36% to 62% [22].

It can be said that this biotransformation has massive impact on dry hop flavour. The literature provides information that only terpenoids undergo biotransformation and there exists no published evidence of the transformation of myrcene, humulene, or caryophyllene. While these hydrocarbon terpenes are not converted, the yeast act as the agent and remove them from solution. Takoi et al. showed that geraniol is metabolized by yeast into β -citronellol rapidly during the primary fermentation in 2-4 days after beginning [8]. Other work showed the bioconversion with yeasts of geraniol to β -citronellol is also accompanied by the by stream synthesis of geranyl acetate and citronellyl acetate [6]. King and Dickinson elaborated the scheme of biotransformation of geraniol and nerol by *S. cerevisiae* for 4 possible outcomes: citronellol, linalool, α -terpineol, and terpin hydrate [7]. This works reveal the huge aroma shaping capacity of dry hopping during lagering.

Additionally innovative solutions of dry hopping systems can also be used for the extraction of flavouring substances from other raw materials e.g. fresh, frozen or dried fruits, spices, oak flakes etc. Relatively small and mobile devices allow very diverse exploitation limited only by resulting sensory characteristic of beer.

References

- [1] W. Kunze, *Technologia piwa i sodu*, Piwochmiel, Warszawa 1999.
- [2] K. Baranowski, Chmielowe akcenty smakowo-zapachowe w piwie? No problem, ale ..., *Przemyst Fermentacyjny i Owocowo - Warzywny*, 11 (2016) 10.
- [3] C. Almaguer, M. Gastl, E.K. Arendt, T. Becker, Contributions of hop hard resins to beer quality, *BrewingScience*, 65 (7-8) (2012) 118-129.
- [4] A. Forster, M. Biendl, C. Schonberger, B. Engelhard, A. Gahr, A. Lutz, W. Mitter, R. Schmidt, *Hops: Their Cultivation, Composition and Usage*, Fachverlag Hans Carl 2014.
- [5] U. Skomra, Chmiel zwyczajny (*Humulus lupulus* L.) Gatunek o szerokim spektrum aktywnoci biologicznej, Instytut Uprawy Nawoenia i Gleboznawstwa (IUNG), <http://pw.ihar.edu.pl/assets/Uploads/1.2-Koryciny-Skomra-kolekcja-chmielu-referat.pdf> (dostep 18.12.2016).
- [6] F. R. Sharpe, D. R. J. Laws, The essential oil of hops – A Review, *Journal of Institute of Brewing*, 87 (1981) 96-107.
- [7] A. J. King, R. J. Dickinson, Biotransformation of hop aroma terpenoids by ale and lager yeasts, *FEMS, Yeast Research*, 3 (2003) 53–62.
- [8] A. J. King, R. J. Dickinson, Biotransformation of monoterpene alcohols by *Saccharomyces cerevisiae*, *Torulaspora delbrueckii* and *Kluyveromyces lactis*, *Yeast*, 16 (2000) 499–506.
- [9] K. Takoi, K. Koie, Y. Itoga, Y. Katayama, M. Shimase, Y. Nakayama, J. Watari, Biotransformation of Hop-Derived Monoterpene Alcohols by Lager Yeast and Their Contribution to the Flavor of Hopped Beer, *Journal of Agricultural and Food Chemistry*, 58 (2010) 5050–5058.
- [10] A. Oberholster, B.M. Titus, Review: Impact of Dry Hopping on Beer Flavor Stability. *Ann Food Process Preserv*, 1(1) (2016) 1004.
- [11] S. Hieronymus, *For the Love of Hops: The Practical Guide to Aroma, Bitterness and the Culture of Hops*, Boulder, Brewers Publications, a division of the Brewers Association, Colorado 2012.
- [12] K.H. Benson, *Metabolomics of Hops and the Brewing Process* [dissertation]. University of California Davis, (2014) 77.
- [13] A.R. Spevacek, K.H. Benson, C.W. Bamforth, C.M. Slupsky, Beer metabolomics: Molecular details of the brewing process and the differential effects of late and dry hopping on yeast purine metabolism, *J Inst Brew*, 122(1) (2016) 21-28.
- [14] A. Mikyka, M. Hrabak, The role of malt and hop polyphenols in beer quality, flavour and haze stability, *J Inst Brew*. 108 (2002) 78-85.
- [15] I.R. McLaughlin, C. Lederer, T.H. Shellhammer, Bitterness-Modifying Properties of Hop Polyphenols Extracted from Spent Hop Material, *Am Soc Brew Chem.*, 66 (2008) 174-183.

- [16] G. Drexler, Dry Hopping, Barth-Haas Hops Academy, Blumenau 2016
http://www.cervecon.com.br/Palestras/Georg_Drexler.PDF (access 18.12.2016)
- [17] A. Forster, A. Gahr, On the fate of certain hop substances during dry hopping, *BrewingScience* 66(7-8) (2013) 93-103.
- [18] M. Schnaitter, A. Kell, H. Kollmannsberger, F. Schüll, M. Gastl, T. Becker, Scale-up of Dry Hopping Trials: Importance of Scale for Aroma and Taste Perceptions, *Chem Ing Tech*, 88(12) (2016) 1955-1965.
- [19] J. Reeves, Apparatus, system and method for adding hops or other ingredients to beverage, US Patent no. 20130202736 A1 (2013), <https://www.google.com/patents/US20130202736> (access 19.12.2016)
- [20] http://braukon.de/wordpress/wp-content/uploads/2016/11/braukon_hops_technology_en_2016.pdf (access 19.12.2016)
- [21] http://www.rolec-prozess-brautechnik.eu/_engl/gfx/Info_ROLEC_DryHOPNIK_E.pdf (access 19.12.2016)
- [22] A. Forster, A. Gahr, F. Van Opstaele, On the transfer rate of geraniol with dry hopping, *BrewingScience*, 67(3-4) (2014) 60-62.